

## General Description

ELS21 is a patented smart optical device, which is usually combined with a hydraulic steering cylinder. The main application is on rough terrain machines, to detect when the wheels are correctly aligned. The alignment occurs when the sensor detects a different refraction index zone, which is marked on the hydraulic cylinder. As the sensor is mounted on the cylinder, the applications can be multiple, wherever a cylinder is present. The product is available in 6 different versions, for example with M12 4 pole standard connector, with 3 pole automotive connectors or with open leads 3 wire in different lengths.

The product is based on reflective sensor as input stage, a computing unit based on microprocessor device and an output high side driver, which is able to drive high current load, up to 700mA.

The sensor includes “smart” functions that are able to improve the life of the system, the reliability (MTTFd>120years) and guarantee the robustness in a harsh environment (temperature variations, cylinder markers wearing, component degradation, presence of electromagnetic disturbs etc.).

## Applications

Steering machines  
Surface cleaning machines  
Rough terrain machines  
Road building machines  
Construction machines  
Agricultural machines  
Logistic machines  
Loaders

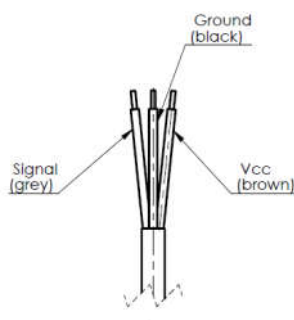

Cable colours

See page 3 for other configurations

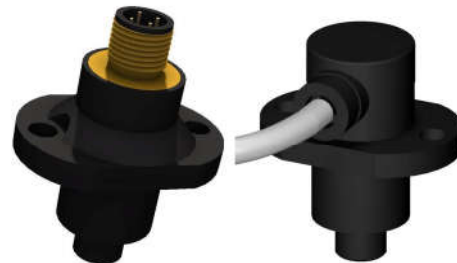

## Features

- High input voltage range
- High temperature range
- High current output
- Meets ISO 7637 normative, including pulse 5 “load dump“
- MTTFd > 120 years
- Inversion of polarity protection
- Overload protection
- Smart interface and smart algorithm
- Compliant to RoHS European Directive
- Designed for earth moving environment
- Customizable on different parameters

## Pin Functions

ELS21-M12 and ELS21-C25-M12

No.	Name	Function
1	V <sub>CC</sub>	Power Supply
2	NC	Do not connect, for internal use only
3	GND	Ground
4	OUT	Output (PNP)

ELS21-CAB and other versions

Cable color	Name	Function
Brown	V <sub>CC</sub>	Power Supply
Black	GND	Ground
Grey	OUT	Output (PNP)

## Ordering Information

<b>ELS21-M12</b>	With a 4 pole M12 male connector, no cable
<b>ELS21-CAB</b>	With a 3.5m cable, open leads
<b>ELS21-AT</b>	With a 50cm cable + Amphenol AT04-3P
<b>ELS21-DTM</b>	With a 50cm cable + Deutsch DTM04-3P
<b>ELS21-DTMi</b>	With a 50cm cable + Deutsch DTM04-3P
<b>ELS21-C25-M12</b>	With a 25cm cable + Binder 4 pole M12 male

## ELS21

### ABSOLUTE MAXIMUM RATINGS

Symbol	Parameter	Min	Max	Unit
T <sub>S</sub>	Storage Temperature	-40	85	°C
T <sub>A</sub>	Operating Temperature Range	-20	80	°C
V <sub>CC</sub>	Supply Voltage Range	7	30	V
I <sub>o</sub>	Max output current (depending on ambient temperature)	700	2400	mA

Stresses beyond those listed under "Absolute Maximum Ratings" may cause permanent damage to the device.

Exposure to absolute maximum rated conditions for extended periods may affect device reliability.

### ELECTRICAL CHARACTERISTICS

T<sub>A</sub> = 25°C, unless otherwise noted.

Symbol	Parameter	Conditions	Min	Typ	Max	Unit
V <sub>CC</sub>	Supply Voltage Range	battery	8	12	30	V
V <sub>J</sub>	Jump start voltage allowable				36	V
OL	Overload protection (output shutdown)	8V < V <sub>CC</sub> < 30V	700		2400	mA
I <sub>CC</sub>	Device current consumption	No load, whole voltage and temperature range		15	30	mA
I <sub>LOAD</sub>	Load current	8V < V <sub>CC</sub> < 30V	1	100	700	mA
V <sub>OH</sub>	Output voltage high	8V < V <sub>CC</sub> < 30V	V <sub>CC</sub> -0.3		V <sub>CC</sub>	V
V <sub>OL</sub>	Output voltage low	V <sub>CC</sub> = 30V R <sub>L</sub> < 30kΩ	0		150	mV
R	Min detection range	I <sub>LOAD</sub> =100mA	3			ms
	Max detection speed (mark width of 3mm)				1	m/s
τ	Response time	ON-OFF I <sub>LOAD</sub> =100mA		20	30	us
		OFF-ON I <sub>LOAD</sub> =100mA		50	100	us

### MECHANICAL CHARACTERISTICS

Symbol	Parameter	Conditions	Min	Typ	Max	Unit
IP	Protection grade	both versions			IP67	
Out	Output configuration	both versions		PNP		
Lc	Length tolerance (cable 3x0.5mm <sup>2</sup> )	cable versions		± 20		mm

### RELIABILITY PARAMETERS

Symbol	Parameter	Value	Unit
MTTF	Mean Time To Failure	120	years
DC	Diagnostic coverage	None	-
S	Structure	Not redundant	-

**MECHANICAL DIMENSIONS ELS21-M12**

The dimensions are expressed in mm, tolerance  $\pm 0.1$  mm.

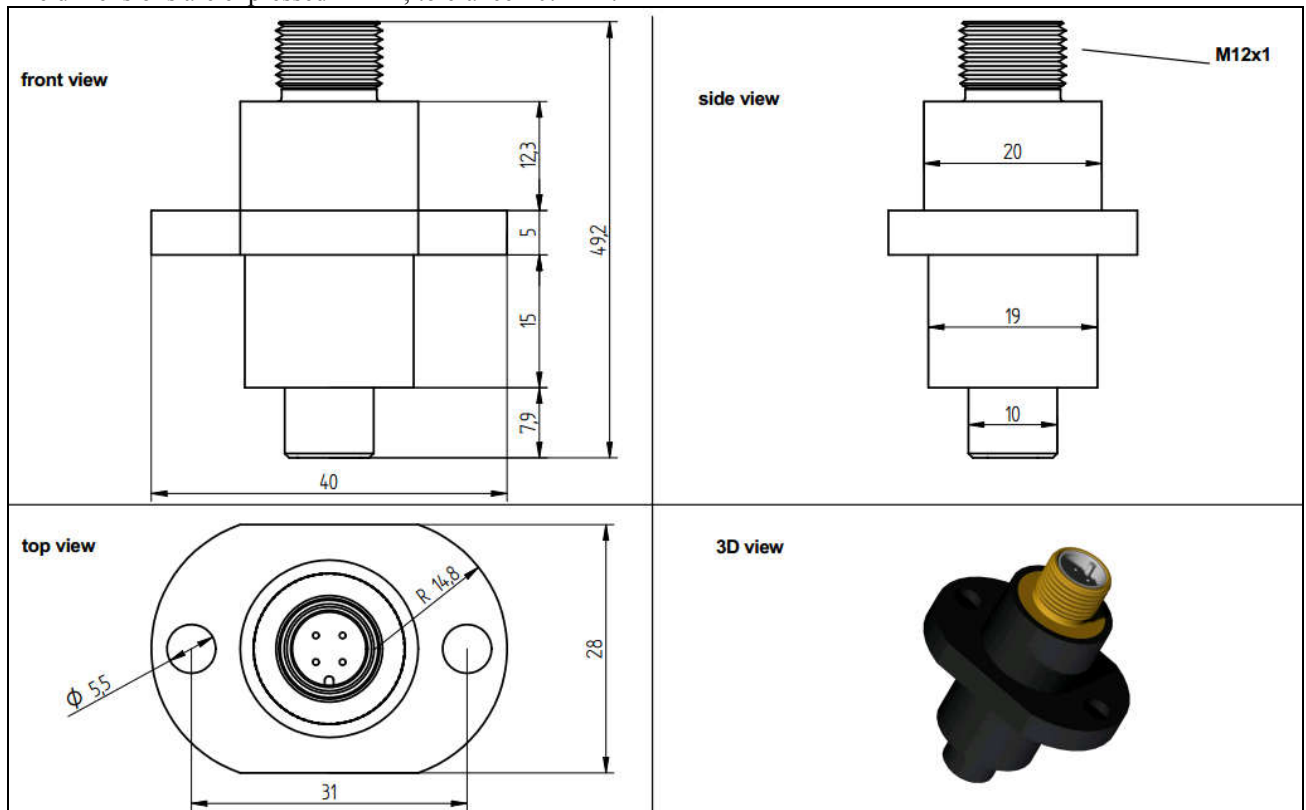

Figure 1 –M12 straight version

**MECHANICAL DIMENSIONS ALL OTHER VERSIONS**

The dimensions are expressed in mm, tolerance  $\pm 0.1$  mm.

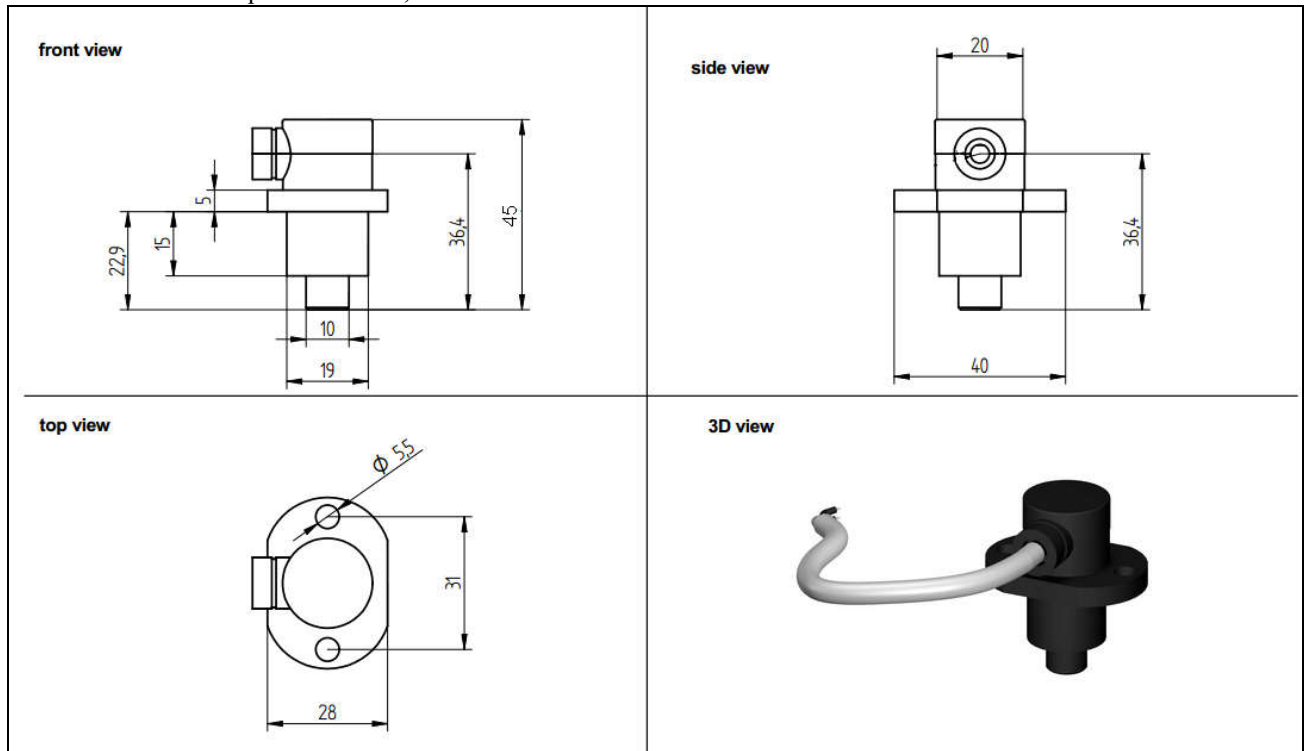

Figure 2 –right angle versions

OUTPUT CONFIGURATIONS

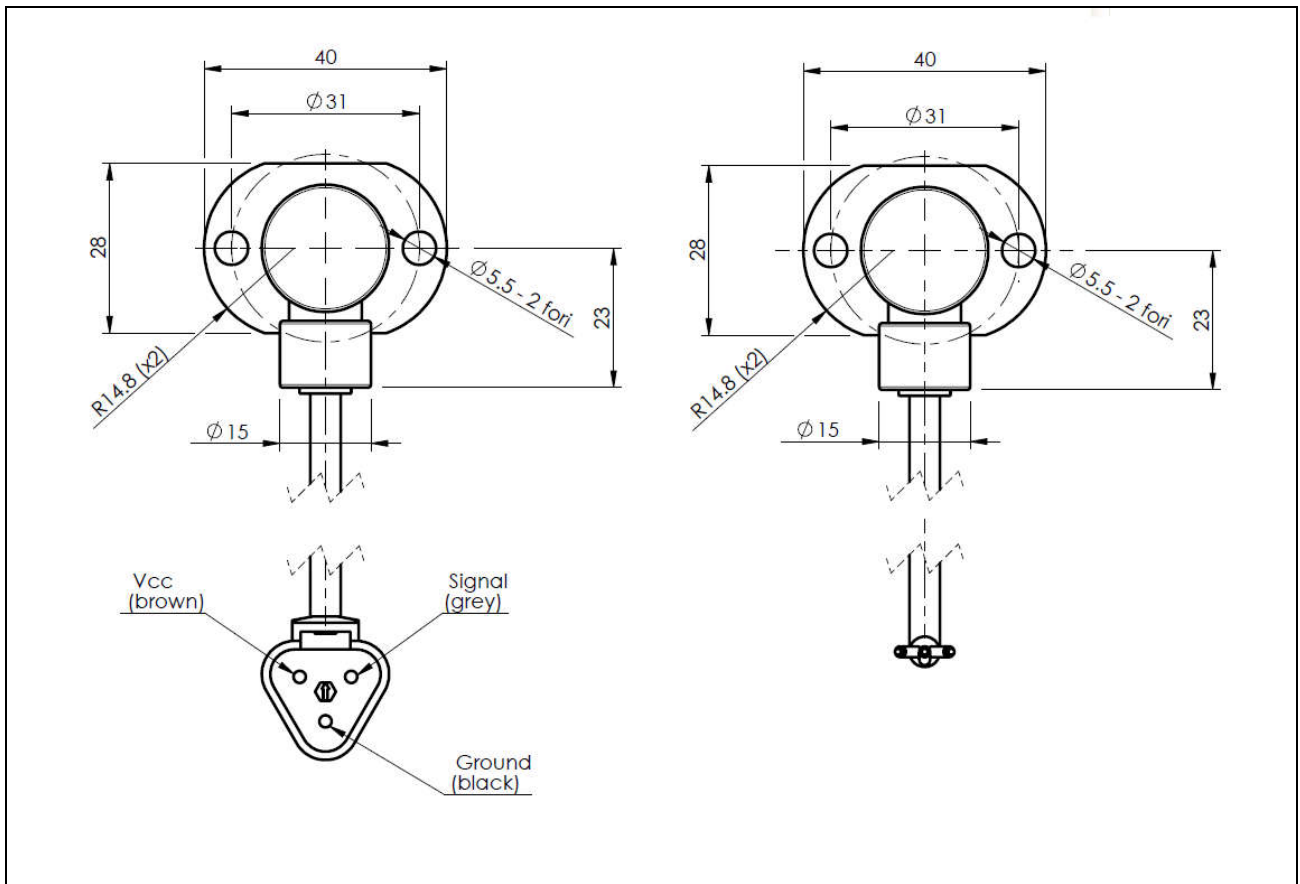

Figure 3 –DT and open leads configuration

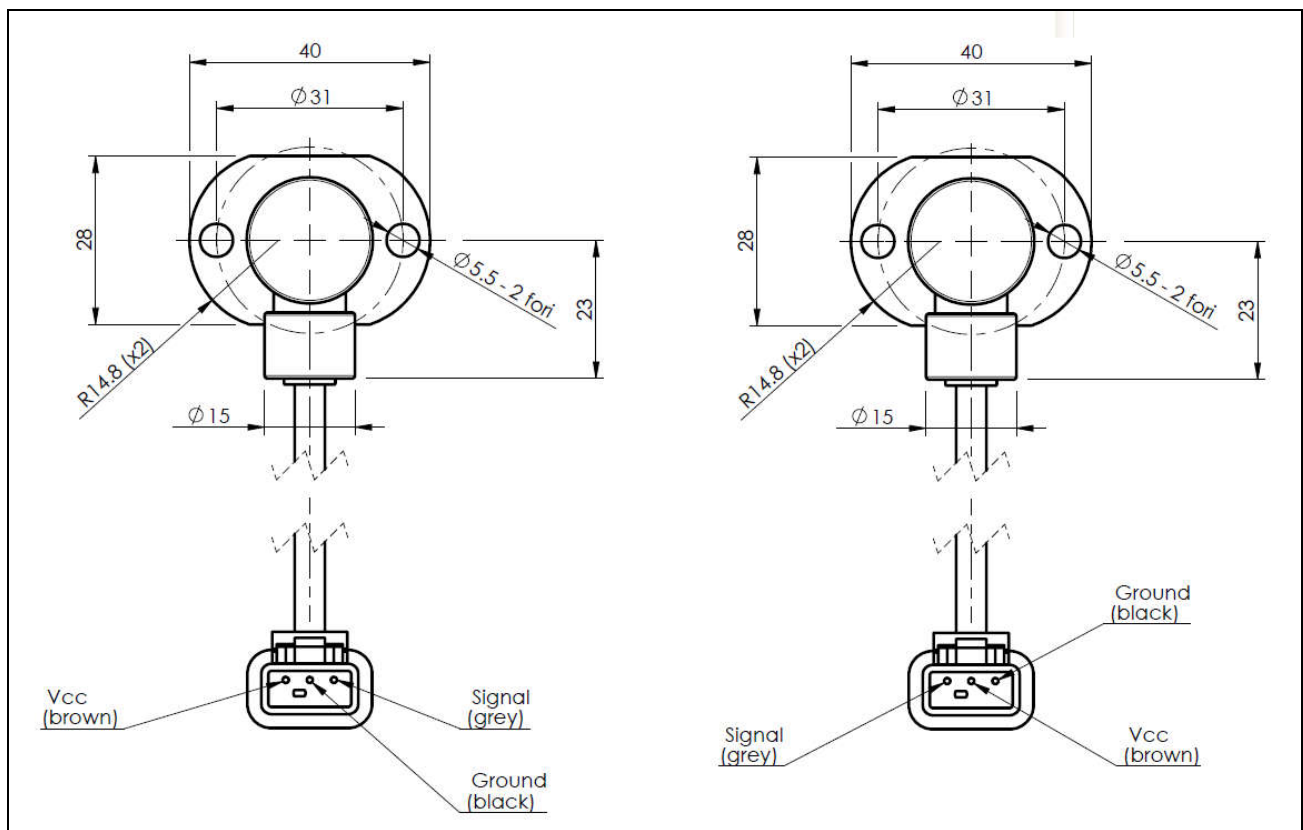

Figure 4 – DTM configurations (DTM and DTMI)

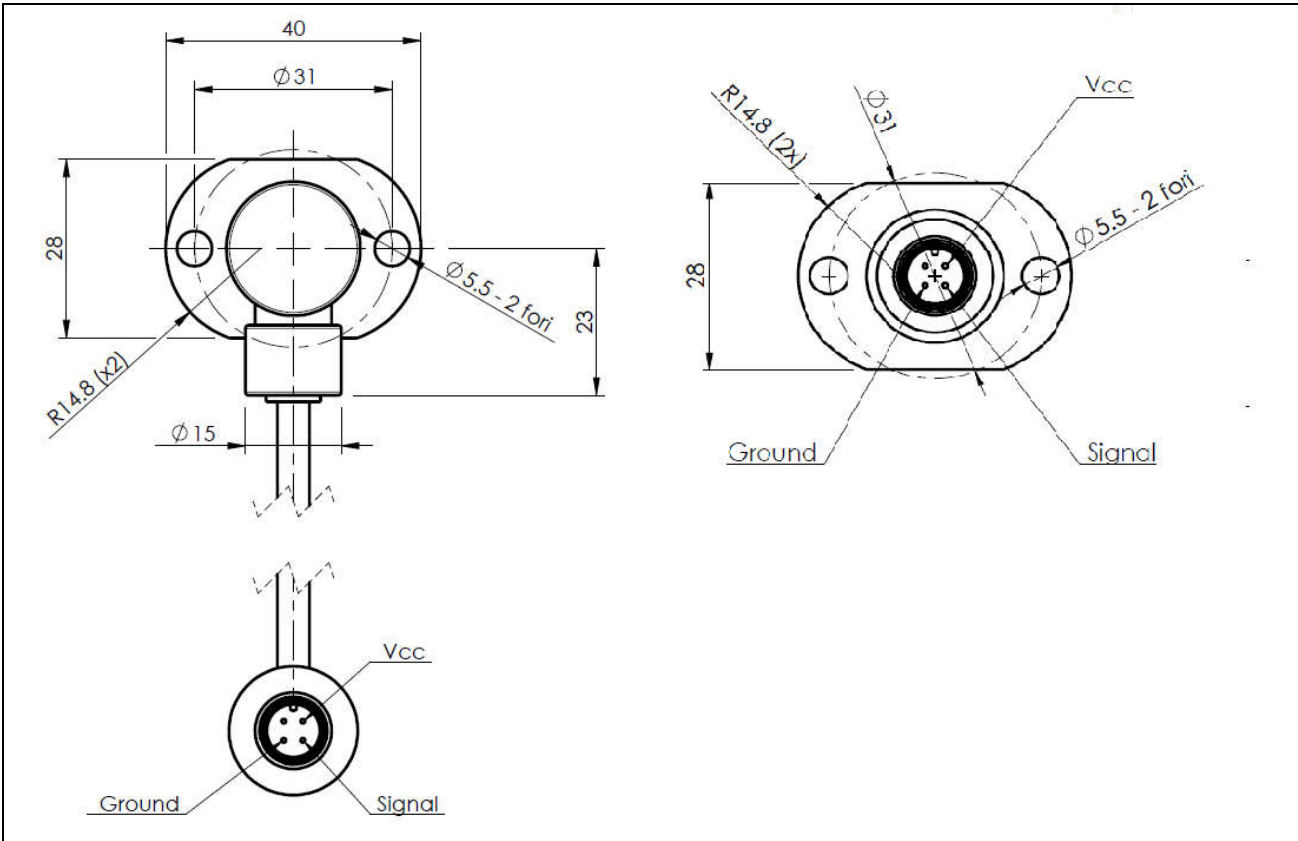

Figure 5 – M12 configurations

**REGULATORY COMPLIANCE TABLE**

Reference normative	Description	Test Type	Status
ISO13766 cl. 5.6	Earth moving machinery: broadband and narrowband emissions from ESA	Emission	pass
ISO13766 cl. 5.6	Earth moving machinery: immunity of ESA to electromagnetic radiation	Emission	pass
ISO13766 cl. 5.8-5.9	Immunity of ESA to electromagnetic radiated, bulk current injection, electrostatic discharge	Immunity	pass
EN 60068-2-6	Sinusoidal vibration test	Environmental test	pass
EN 60068-2-27	Shock test	Environmental test	pass
ISO 7637-2	Road vehicles — Electrical disturbances from conduction and coupling, for 12 volt systems	Immunity	pass
ISO 7637-2	Road vehicles — Electrical disturbances from conduction and coupling, for 24 volt systems	Immunity	pass
EN 60529	Degrees of protection provided by enclosures	Dust and water protection	IP67

**Table 1 – compliance table**

Application circuits

Resistive load

A typical output load is a lamp. For such resistive loads no precautions shall be taken: the output stage is protected against reverse of polarity, short circuit and temperature. The power absorbed by the output stage is equal to  $R_{\text{DS(on)}} * I_{\text{load}}$ .

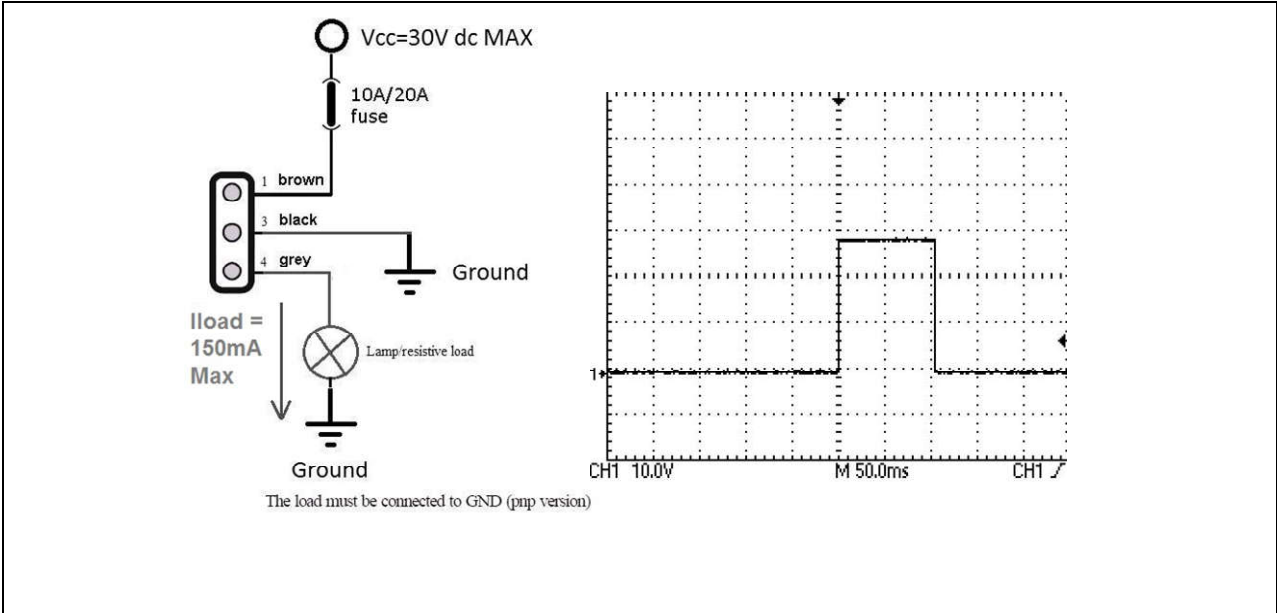

Figure 6 – resistive load connection and VOUT transition graph

Inductive load

Inductive loads are described by inductance L and resistance R. At switch ON, the inductive load causes a slow current ramp up, based on the time constant  $\tau=L/R$ . At switch OFF, due to inductance, the current attempts to continue to flow in the same direction, which causes the load voltage to invert.

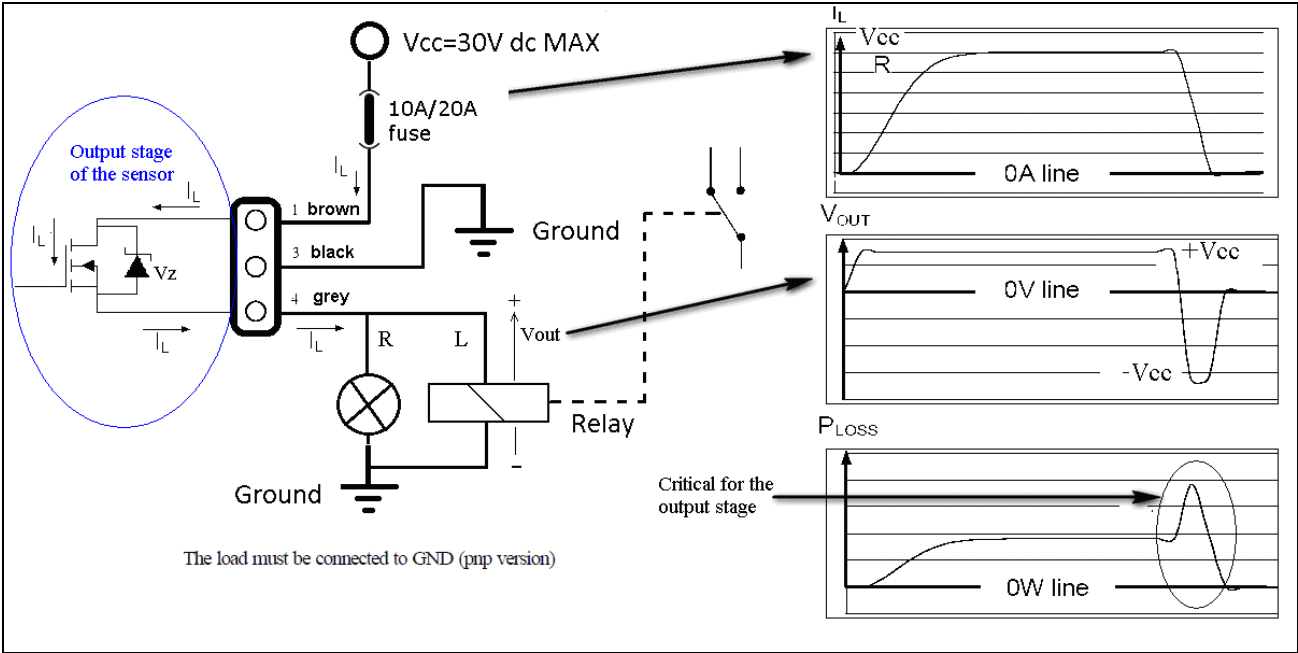

Figure 7 – inductive load connection without protection

In this case, depending on the supply voltage and on the time constant, there is a real risk to break the output stage of the sensor. The output stage is composed of a logic stage, a power mosfet and a zener diode: the diode protects the output against overvoltages.

If the  $V_{DS}$  of the output stage during the transitory becomes very high (double the  $V_{CC}$  value) for long period, it can destroy the mosfet or the zener protection diode inside the output stage.

In order to avoid this possible situation, the use of a freewheeling diode in parallel to the load is recommended.

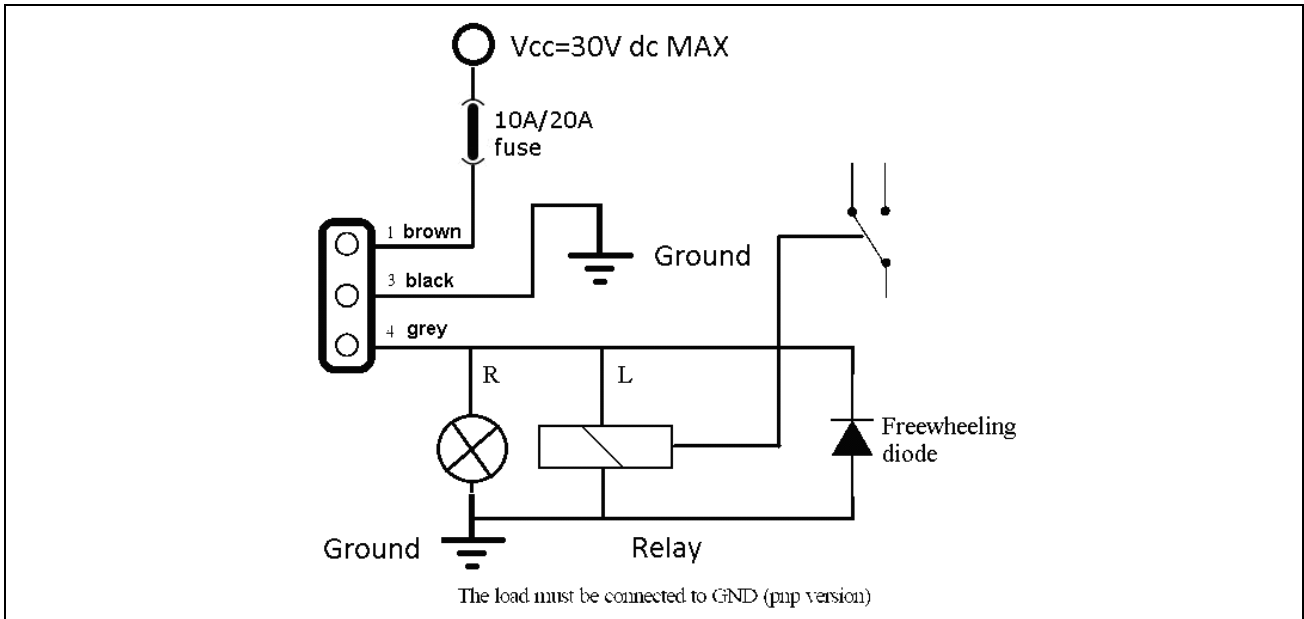

Figure 8 – inductive load connection with protection freewheeling diode

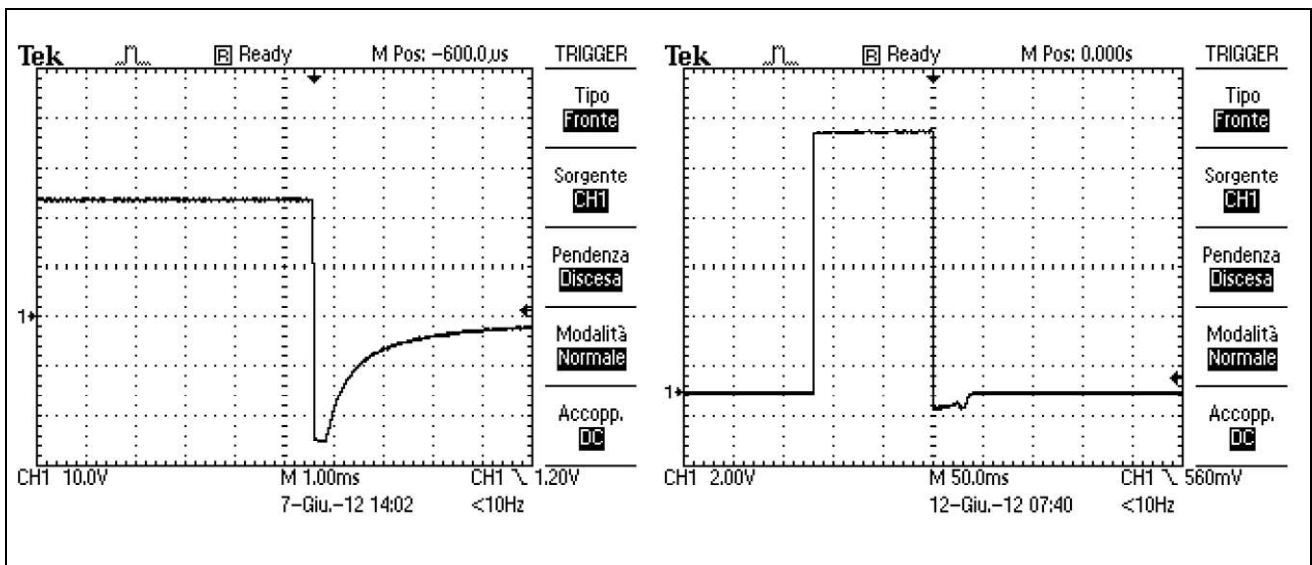

Figure 9 –  $V_{OUT}$  transitions without and with freewheeling diode



## Load dump considerations

Load dump means the disconnection of a powered load. It can cause large voltage spikes from the inductive generator(s). In automotive electronics, it refers to the disconnection of the vehicle battery from the alternator while the battery is being charged. Due to such a disconnection of the battery, other loads connected to the alternator see a surge in power line.

Load dump may occur as a result of cable corrosion, poor connection or of intentional disconnection with the engine running.

The pulse shape and parameters for an alternator with no centralized load dump suppression (pulse 5a ISO7637-2) are given in Figure 10 left side. The pulse shape and parameters for an alternator with centralized load dump suppression (pulse 5b) are given in Figure 10 right side.

The ELS21 is protected against load dump disturbs (see ISO7637-2 pulse 5a) at 12V and at 24V: the load dump amplitude is suppressed (clamped) by the addition of a limiting device. Anyway, as the limiting device is dimensioned based on the information of Figure 10, if a stronger disturb occurs (in amplitude and/or in time duration) the protection device may fail. The failure mode of load dump protection is the short circuit: for this reason the power line of the sensor must be protected using an appropriate fuse. A 10A or 20A automotive fuse is effective.

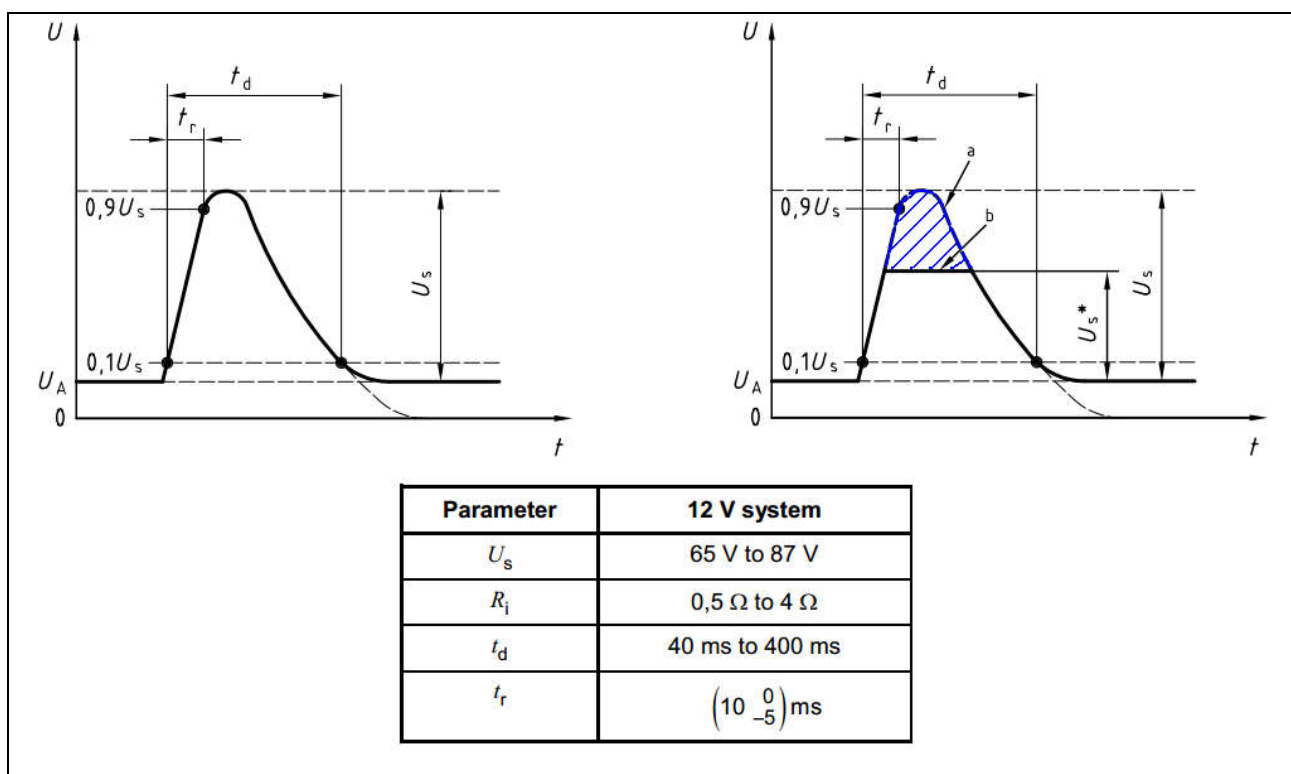

Figure 10 – Load dump typical waveform at 12V: pulse a (unsuppressed) and pulse b (suppressed)